

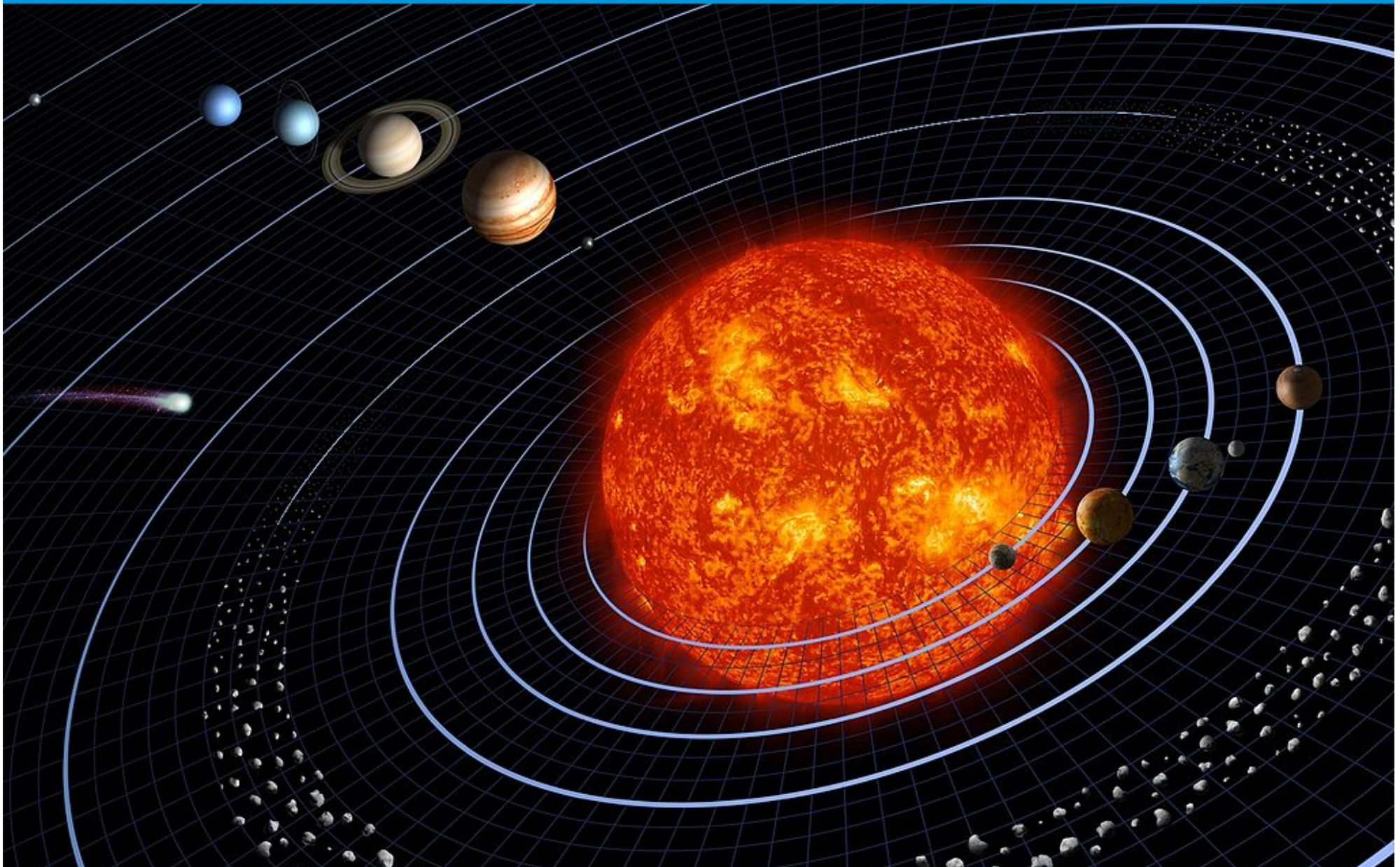

**BepiColombo**  
→ Exploring Mercury



# ESA / JAXA BepiColombo Mercury space mission



# ESA / JAXA BepiColombo Mercury space mission

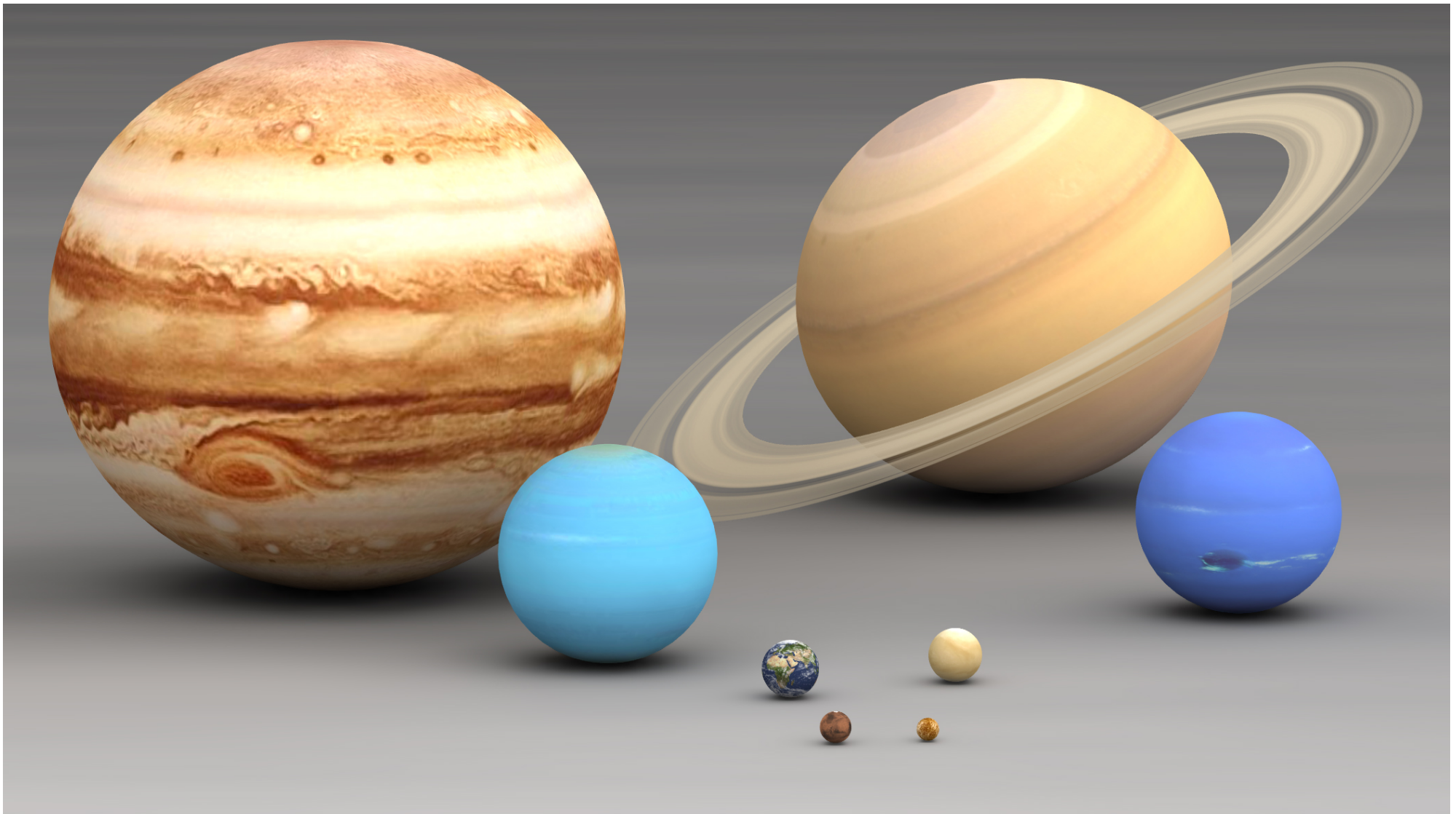

# ESA / JAXA BepiColombo Mercury space mission

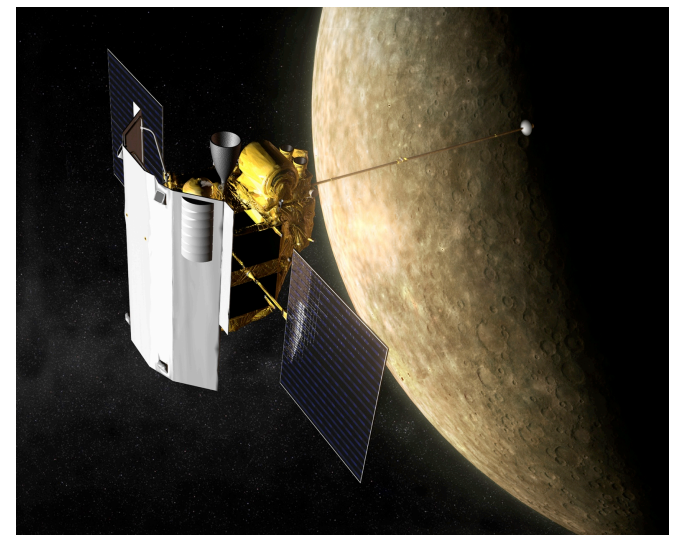
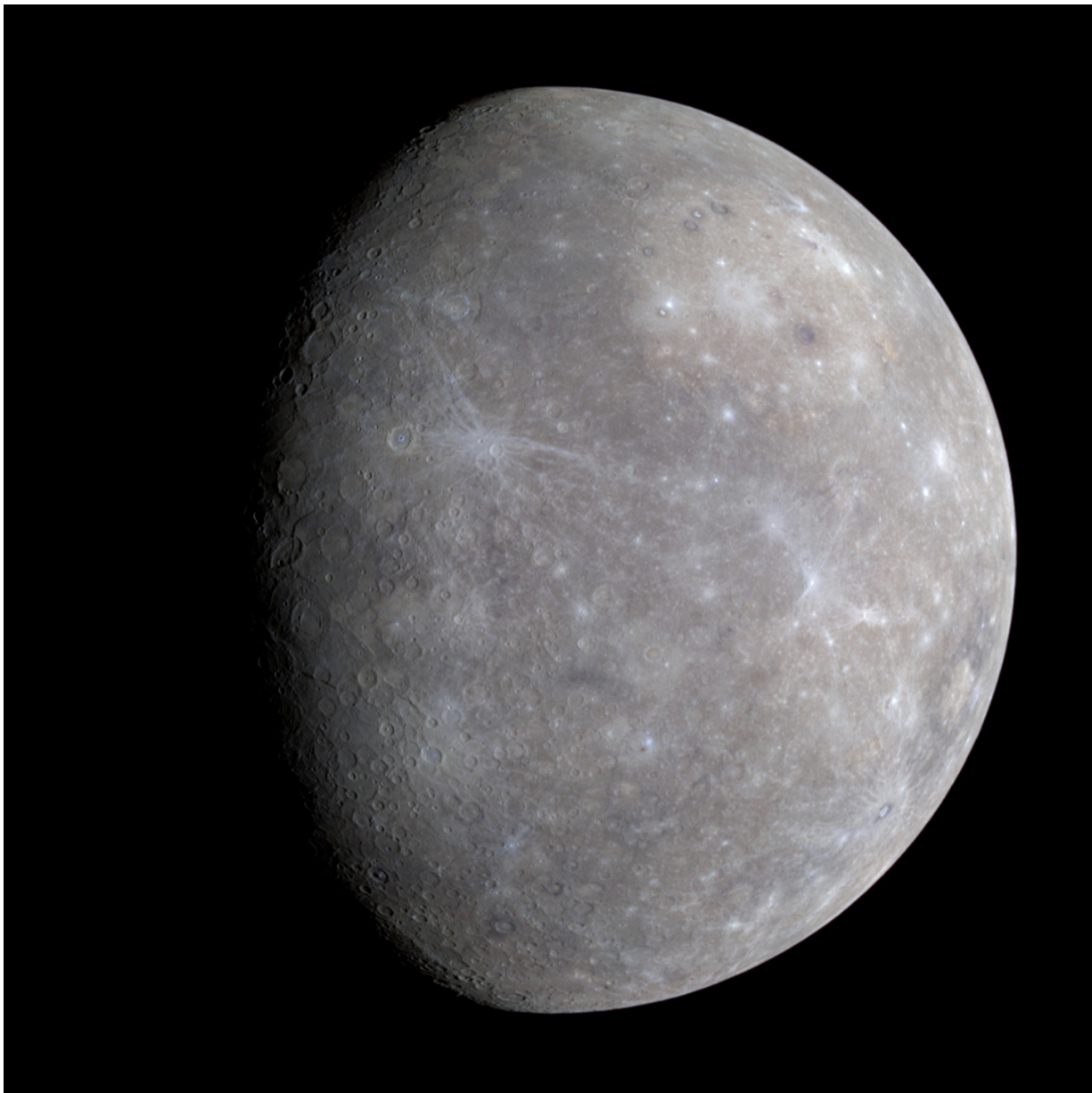

# ESA / JAXA BepiColombo Mercury space mission



**Mercury** has always been something of a puzzle for planetary scientists. Its close position to the Sun means it is very difficult to observe. **Mercury** is a poorly explored planet and **BepiColombo** will be taking a much closer look than its 2 predecessors.

**BepiColombo** is a joint mission of the **European Space Agency** (ESA) and the **Japan Aerospace Exploration Agency** (JAXA) to the planet **Mercury**, executed under ESA leadership. MOU in 2007.



**BepiColombo** is named after Giuseppe (Bepi) Colombo (1920–1984), scientist, mathematician and engineer at the University of Padua, Italy, who first implemented the interplanetary gravity-assist maneuver during the 1974 Mariner 10 mission, a technique now commonly used by planetary probes.

The mission was approved in February 2007 as part of the ESA **“Cosmic Vision”** space science programme.

European Space Agency

# ESA / JAXA BepiColombo Mercury space mission



The main **scientific objectives of the mission** are:

- Study the origin and evolution of a planet close to its parent star
- Study Mercury as a planet - its form, interior, structure, geology, composition and craters
- Investigate Mercury's exosphere, composition and dynamics, including generation and disappearance
- Study Mercury's magnetized envelope (magnetosphere) - structure and dynamics
- Investigate the origin of Mercury's magnetic field
- Verify Einstein's theory of general relativity by measuring the parameters gamma and beta of the parameterized post-Newtonian formalism with high accuracy.

The mission presents enormous, but exciting challenges. After Mars Express, Venus Express and the Huygens probe to Titan, ESA will explore, with JAXA, a planet that is very close to the Sun, key to understanding the formation of our Solar System, and yet still very mysterious.

# ESA / JAXA BepiColombo Mercury space mission



The scientific mission is composed of 2 orbiters:

- the **Mercury Planetary Orbiter (MPO)** built by **ESA**. Will study the surface and internal composition of the planet.
  - (Payload of 11 instruments, comprising cameras, spectrometers (IR, UV, X-ray,  $\gamma$ -ray, neutron), radiometer, laser altimeter, magnetometer, particle analyzers, Ka-band transponder, and accelerometer, provided by Principal Investigators through national funding by ESA Member States).
- the **Mercury Magnetospheric Orbiter (MMO)** built by **JAXA**. Will study Mercury's magnetosphere, that is, the region of space around the planet that is influenced by its magnetic field. (Payload of five advanced scientific experiments, including a magnetometer, ion spectrometer, electron energy analyzer, cold and energetic plasma detectors, plasma wave analyzer, and imager. These will be provided by nationally funded Principal Investigators, one European and four from Japan).

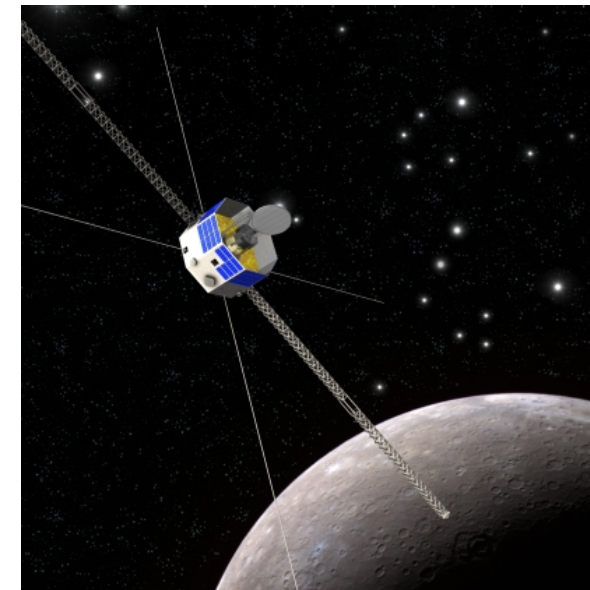
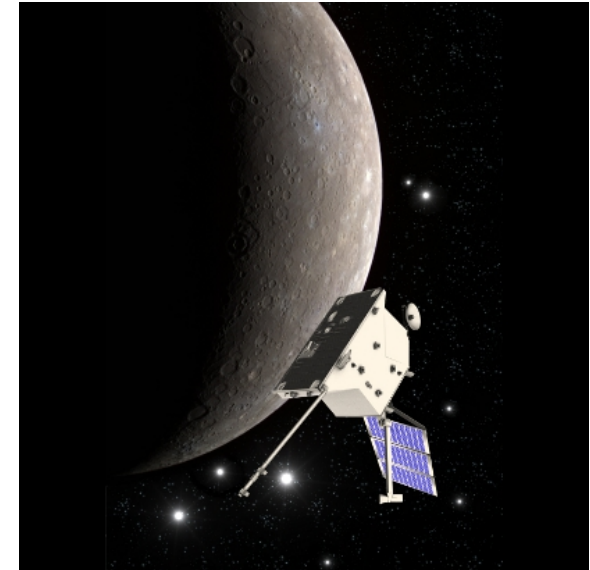

# ESA / JAXA BepiColombo Mercury space mission



For the launch and journey to Mercury, the MPO and the MMO will be carried as part of the **Mercury Composite Spacecraft** (MCS), built by ESA, which, in addition to the two orbiters, comprises:

- the **Mercury Transfer Module** (MTM), providing solar-electric propulsion and all services not required in Mercury orbit, and
- the **MMO Sunshield and Interface Structure** (MOSIF), which provides thermal protection and the mechanical and electrical interfaces for the MMO.

Note: the MPO provides the MMO with the necessary resources and services until it is delivered into its mission orbit, when control is assumed by JAXA.

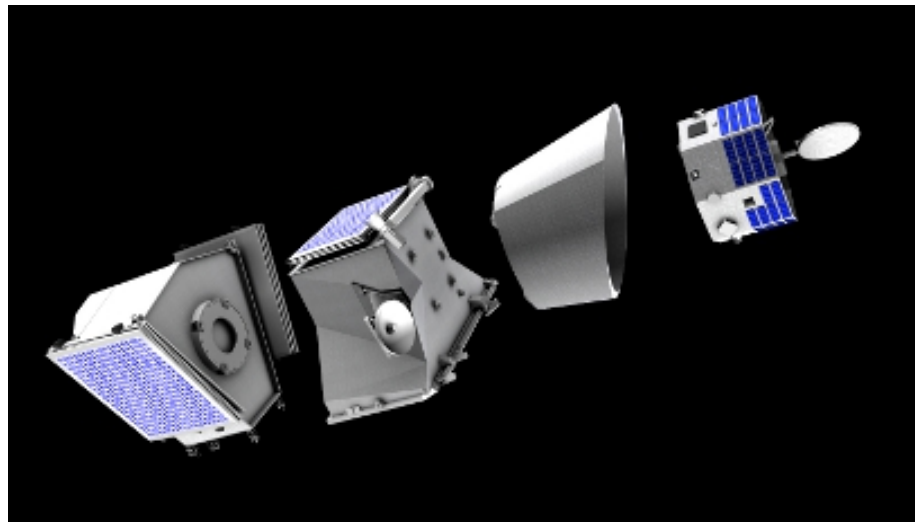



# ESA / JAXA BepiColombo Mercury space mission

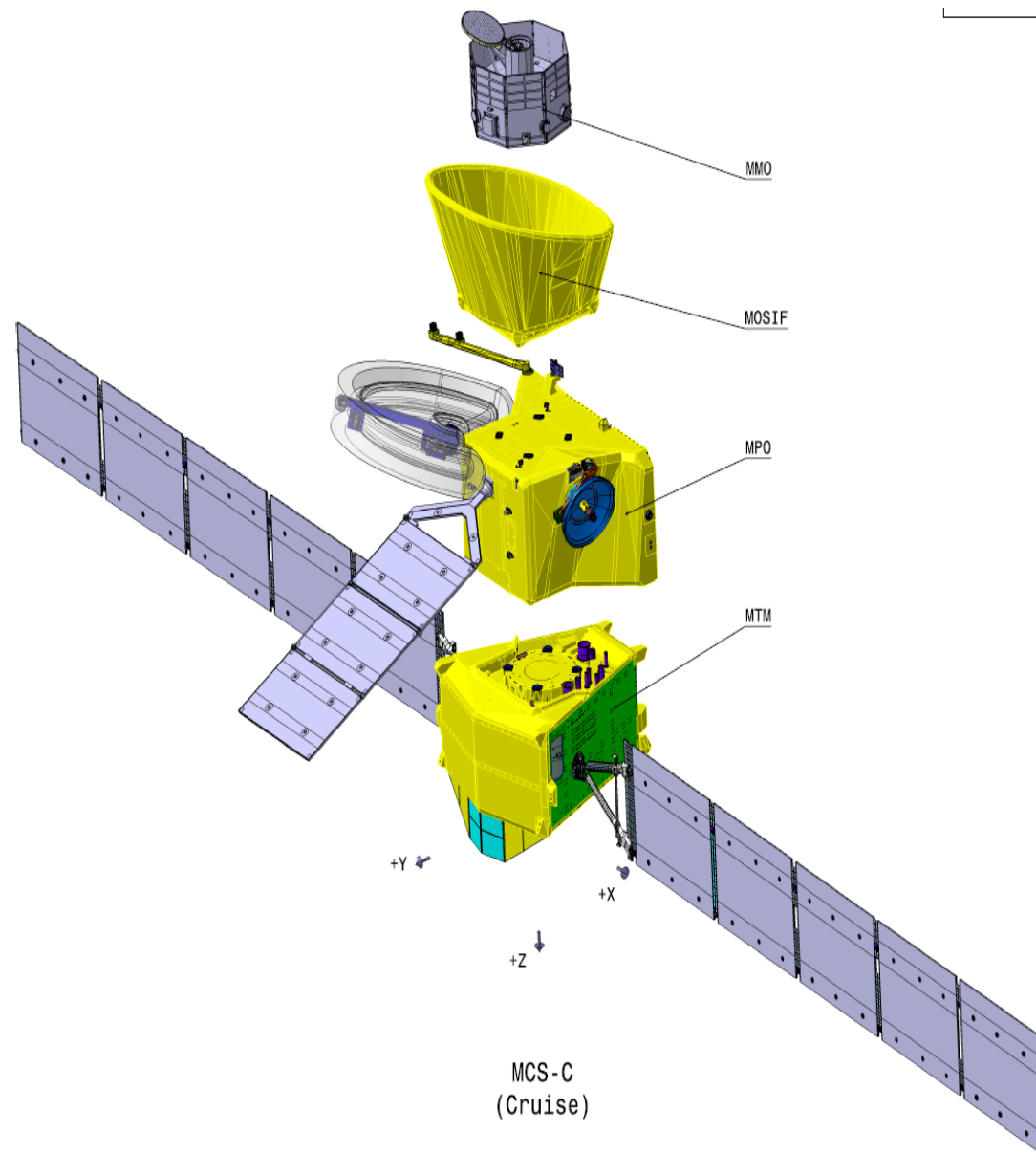
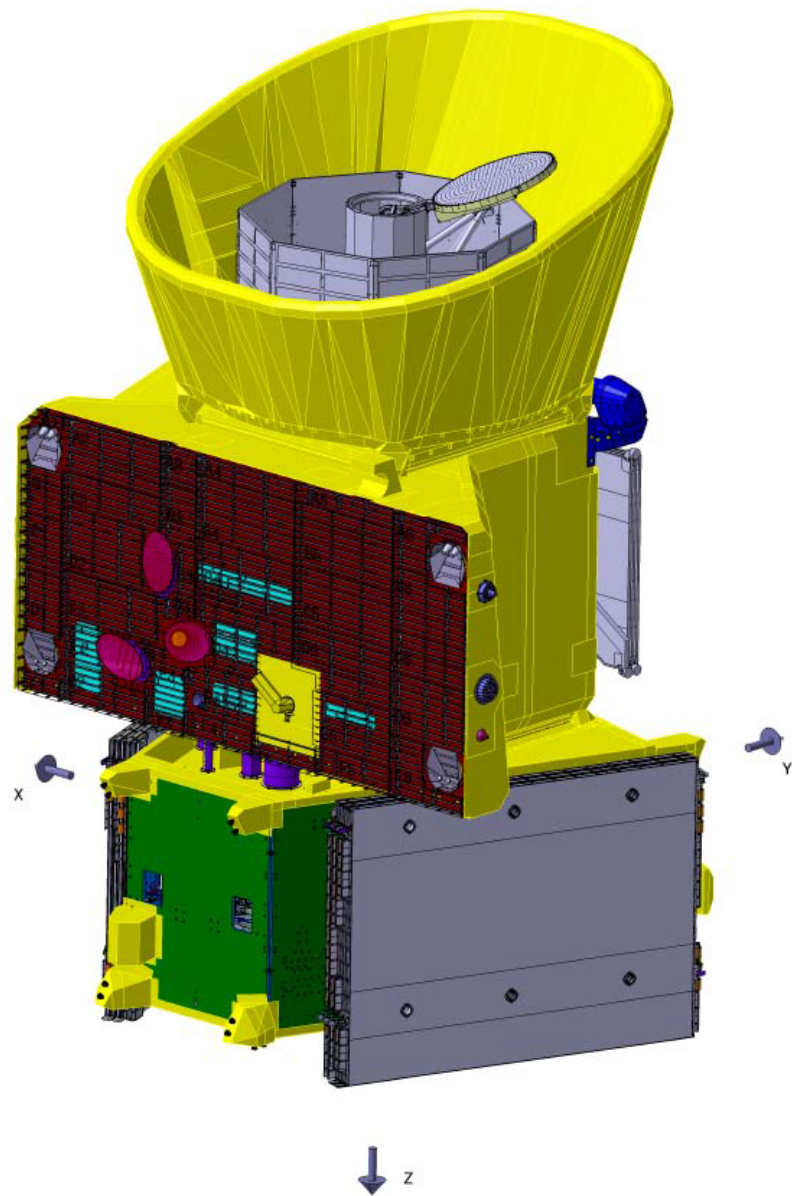

# ESA / JAXA BepiColombo Mercury space mission



The prime contractor for ESA is EADS **Astrium Germany** (Airbus group).

ESA is responsible for the overall mission, the design, development assembly and test of the propulsion and MPO modules, and the launch by an **Ariane 5** vehicle in July 2016 (mass at launch: 4,1t).

Arriving in Mercury orbit in 1 January 2024 after an interplanetary cruise using solar-electric propulsion (ion thrusters), **MMO** and **MPO** will then separate and observe Mercury in collaboration for 1 Earth year (4 Mercury years), with a possible 1 year extension.

The BepiColombo Science Operation Centre will be at the European Space Astronomy Centre (ESAC) in Villafranca, near Madrid, Spain. It will define and coordinate the scientific observations, and assist the teams in operating their instruments.

With two spacecraft, BepiColombo is a large and costly mission, one of the 'cornerstones' in ESA's long-term science programme.

# ESA / JAXA BepiColombo Mercury space mission



## **JAXA-ESA interactions:**

1. Technical Progress Meetings:
  - several meetings per year
  - regular Video-conferences
2. Science Working Team Meetings
  - once per year
  - one out of three meetings held in Japan
  - last: 16th-18th Sept. 2014, @Rikkyo, University in Ikebukuro, Tokyo
3. Common science archive
4. Coordinated science operations
5. Discipline science working groups

# ESA / JAXA BepiColombo Mercury space mission



# ESA / JAXA BepiColombo Mercury space mission

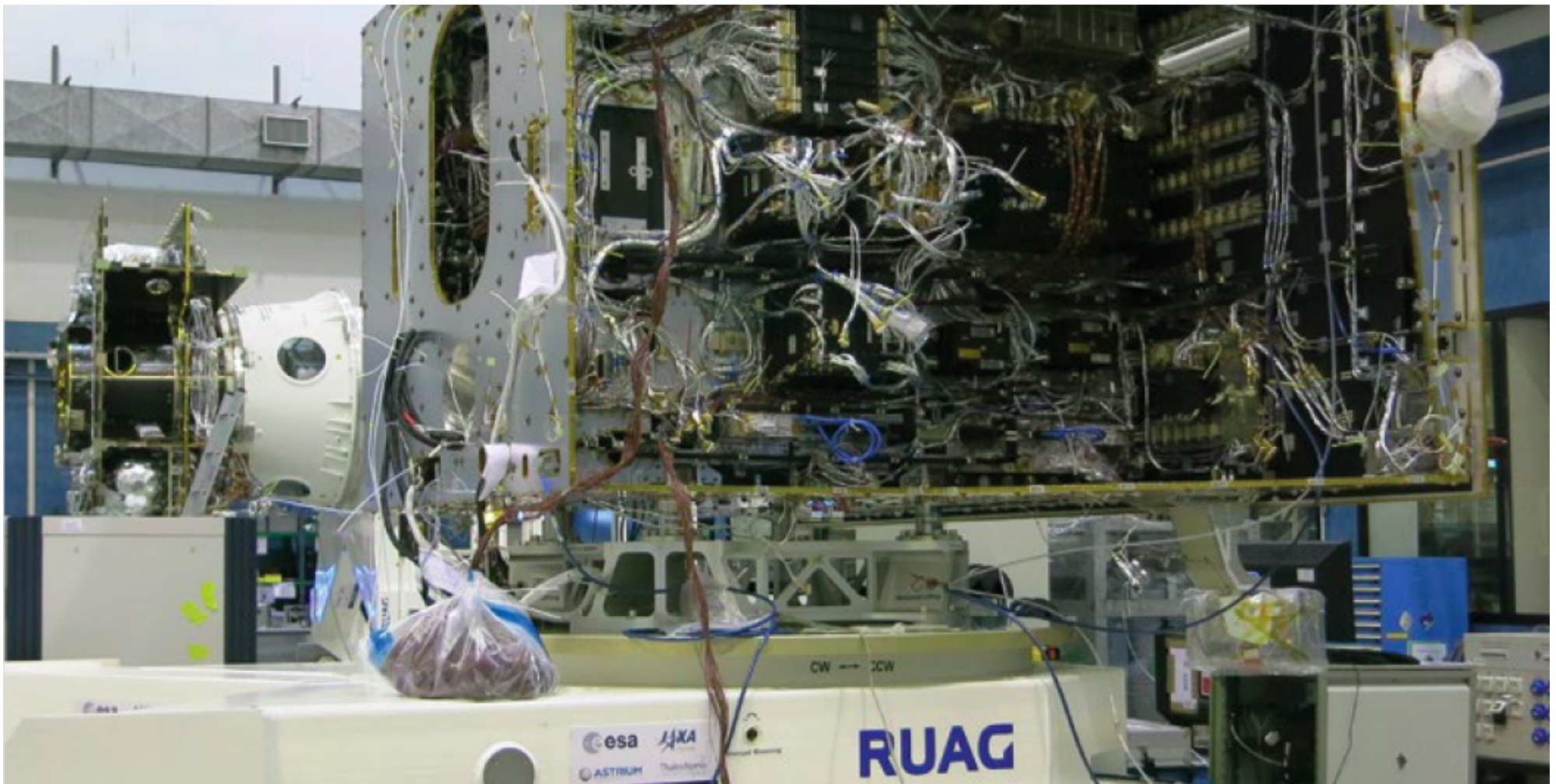

# ESA / JAXA BepiColombo Mercury space mission

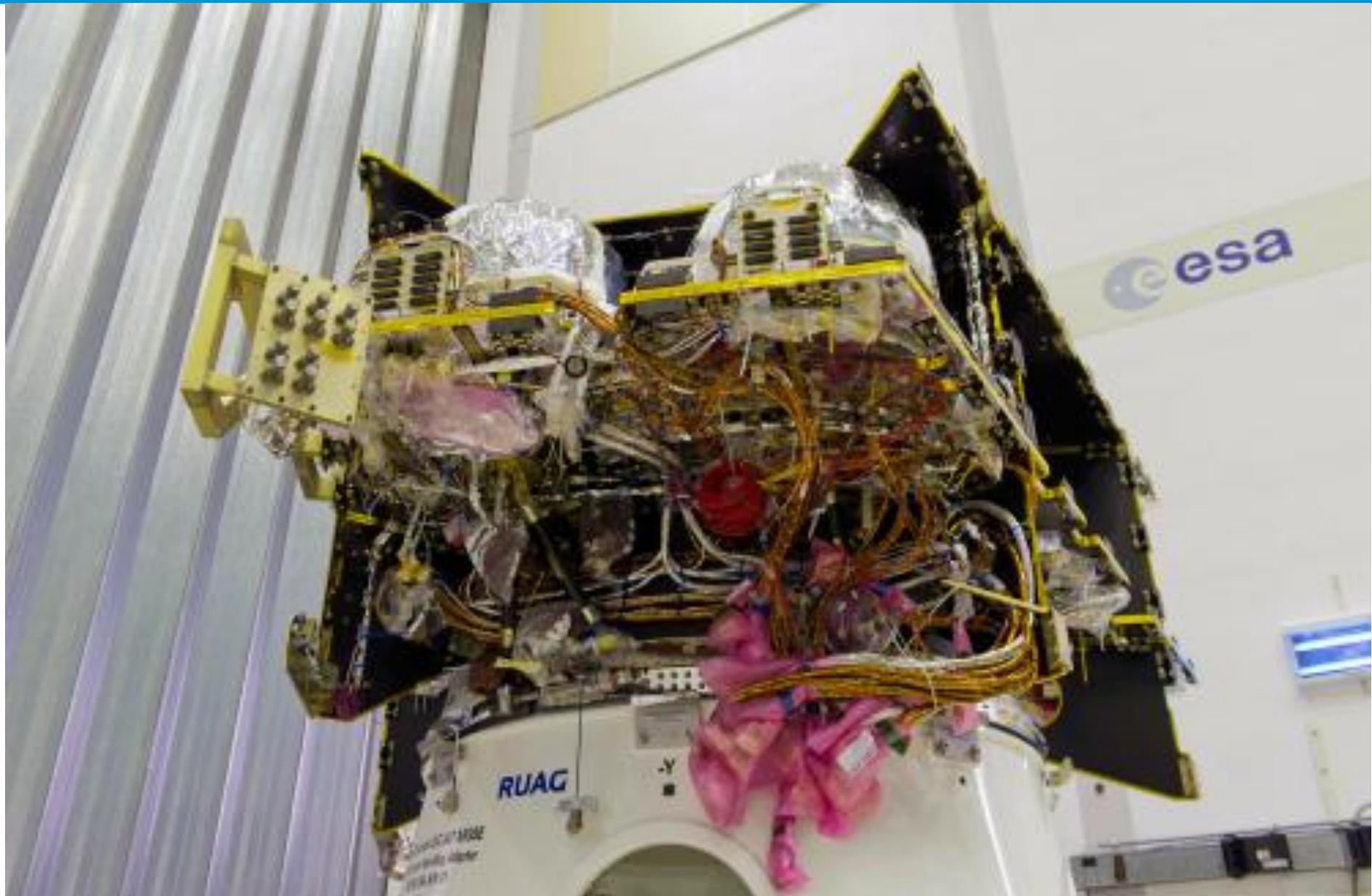

# ESA / JAXA BepiColombo Mercury space mission



Thank you

Jean-Charles Bigot  
ESA ([jcbigot@esa.int](mailto:jcbigot@esa.int))