

# OXFORD SPACE SYSTEMS

deployable spacecraft structures

Design, development and delivery of innovative, cost-reducing  
deployable structures for the global space industry.

**MIKE LAWTON**  
**FOUNDER & CEO**

**EU-JAPAN PARTNERING SPACE  
SECTOR MISSION**

**9-11 MARCH 2015**



# Oxford Space Systems

New venture, but with over 3 years' experience, located at the Harwell Space Cluster – the centre of the UK's space activity.

- ❑ **Mission:** to be recognised leaders in innovative deployable structures based on new, as well as conventional materials, that address the needs of the 'new space' industry.
- ❑ Invited onto 5 key development projects by Airbus, LuxSpace, Thales etc
- ❑ Highly experienced & diverse industry team
- ❑ Backed by venture capitalists, Longwall Ventures
- ❑ Easy access to extensive facilities on site for AIT
- ❑ Strong interest in OSS technology in EU, US and Japan



# Core Team

(excludes contractors)



## Mike Lawton

Founder & CEO

- 2x successful entrepreneur
- Entrepreneur of Year Award
- IMechE Design of Year Award



## Dr. Juan Reveles

Technical Director

- 15 years of complex systems experience: automotive & space
- Award-winning PhD research



## Vincent Fraux

Lead Mechanical Engineer

- 7 years space hardware experience
- Published: *Novel Large Deployables*
- MSc Astronautics & Space Engineering

*Management Team*

*Key Collaborators*



## Prof. Zhong You (PhD. MS BS)

Key Collaborator

- Origami expert
- Professor of Engineering Science
- Expert in closed kinematic chain structures



## Martin Humphries

Key Collaborator

- ESA recognised expert in space mechanisms
- Ex Head of Mechanisms at BAE Systems
- 25+ years space flight design, 40+ successful flight missions



### Collaborators & customers



# Technical & Business Support Network

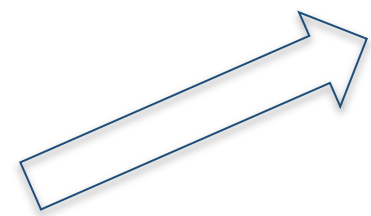
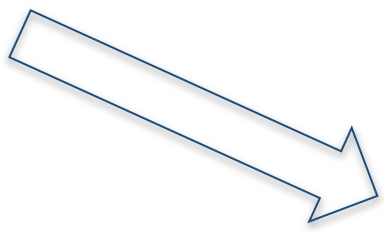



# PRODUCT PORTFOLIO

# 1. DEPLOYABLE PANELS



- Patch antenna platform
- Thermal radiators
- Solar arrays

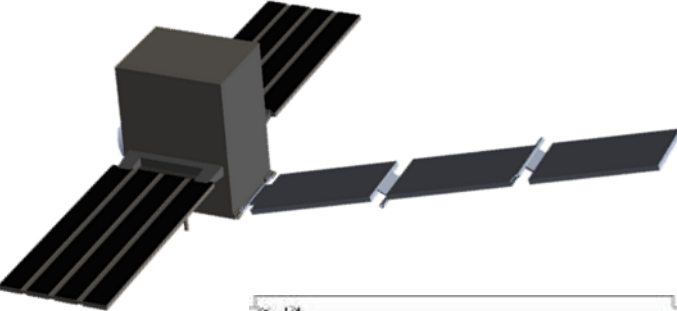
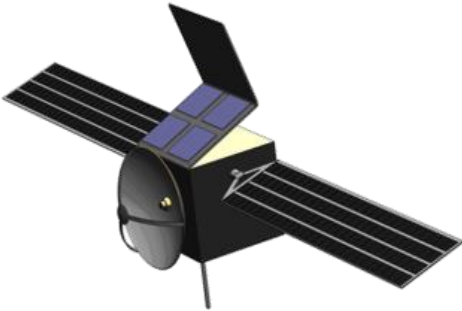

**Composite hinge system:**  
✓ Damped & synchronised  
✓ Lower mass, complexity & cost

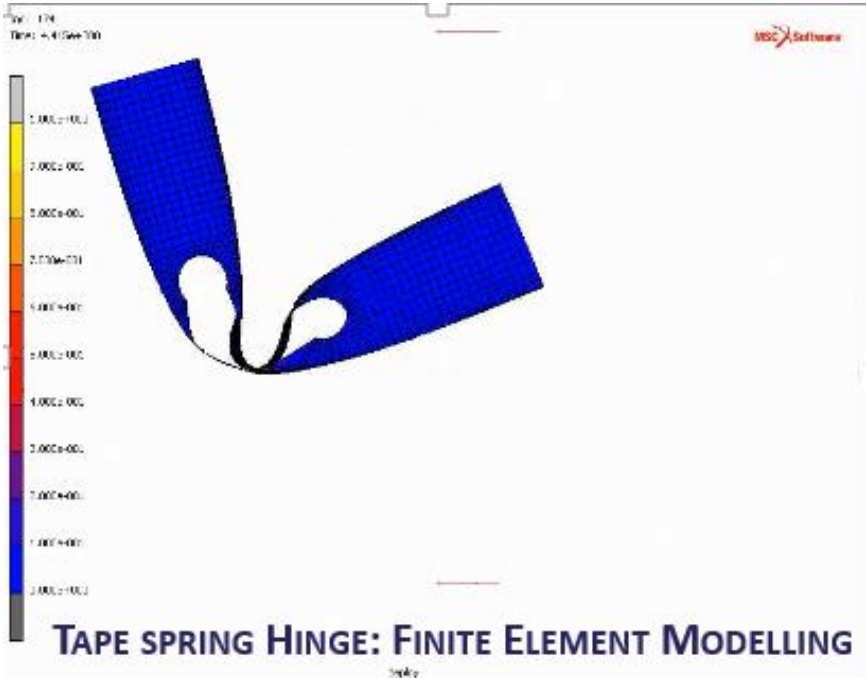

Videos  
removed  
due to file  
size

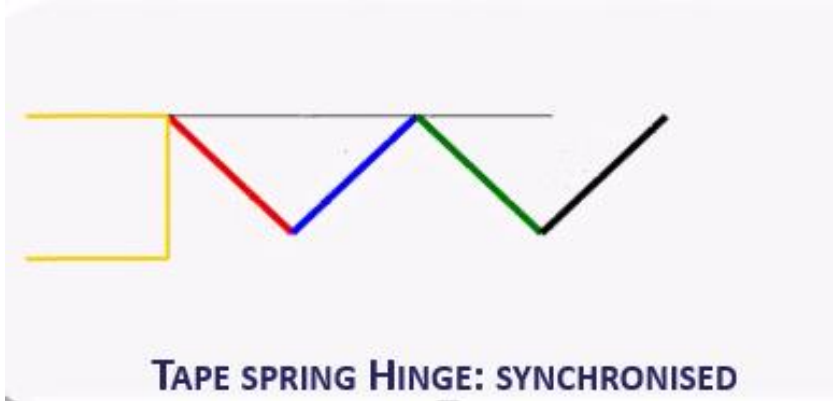

### 1. DEPLOYABLE PANELS



- Patch antenna platform
- Thermal radiators
- Solar arrays

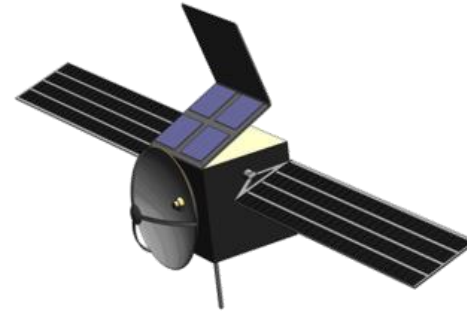

### 2. DEPLOYABLE BOOMS



#### LOW PRECISION

- De-orbit sails
- Solar sails
- Integrated antennas
- CubeSat compatible



#### PRECISION

- High mass payloads
- EP placement

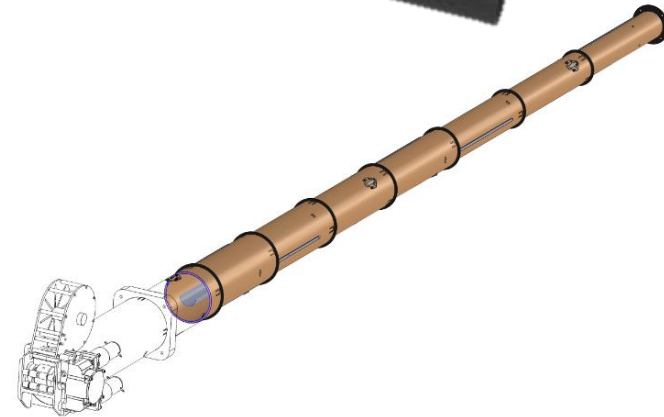

### 3. LARGE DEPLOYABLE ANTENNAS



- Earth observation
- Telecomms
- Data Relay (EDRS)

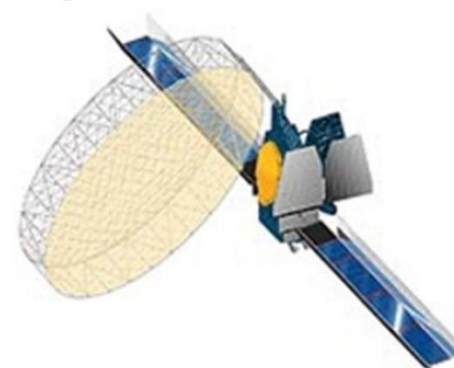

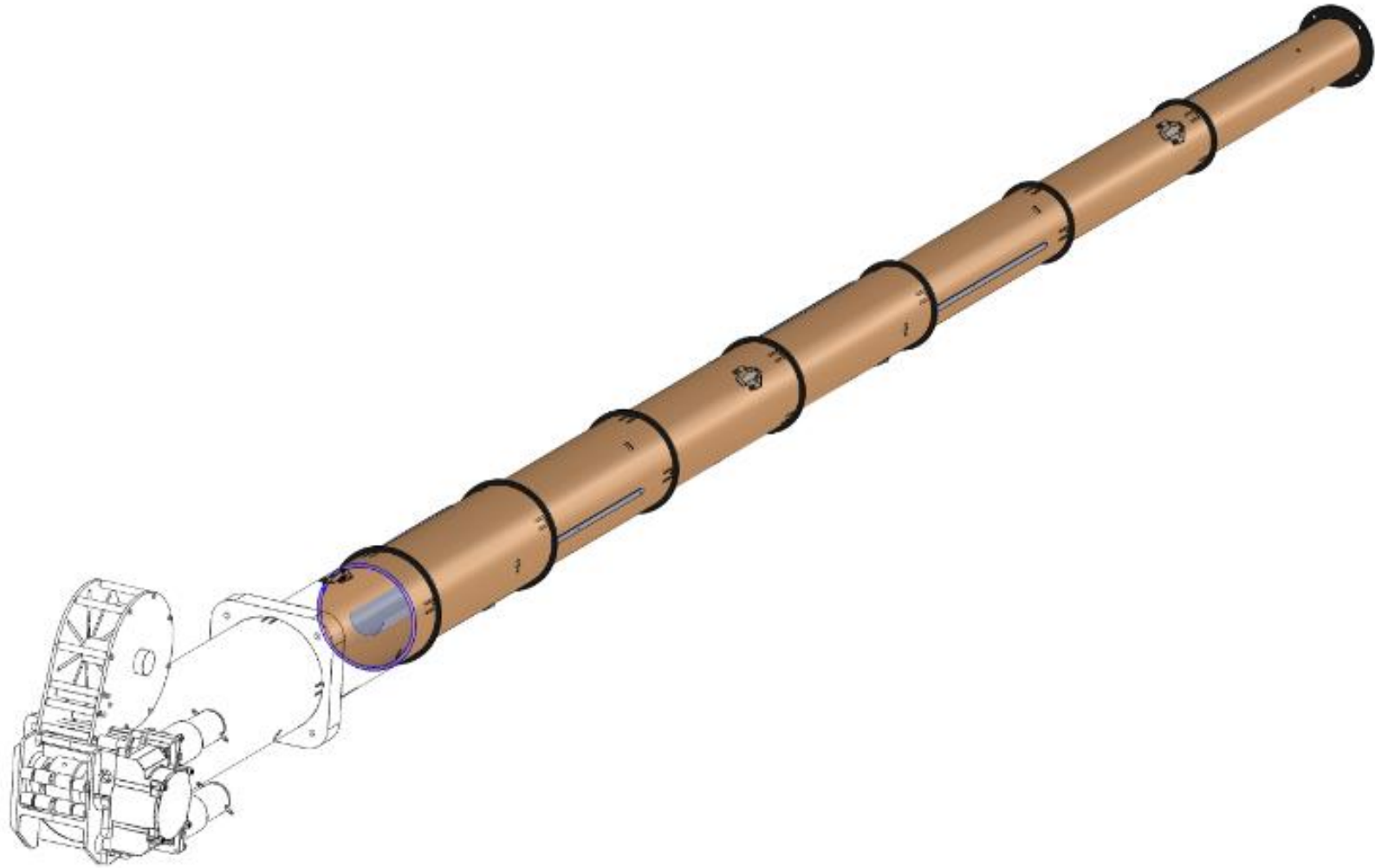

# DEPLOYABLE EXTENDABLE BOOMS



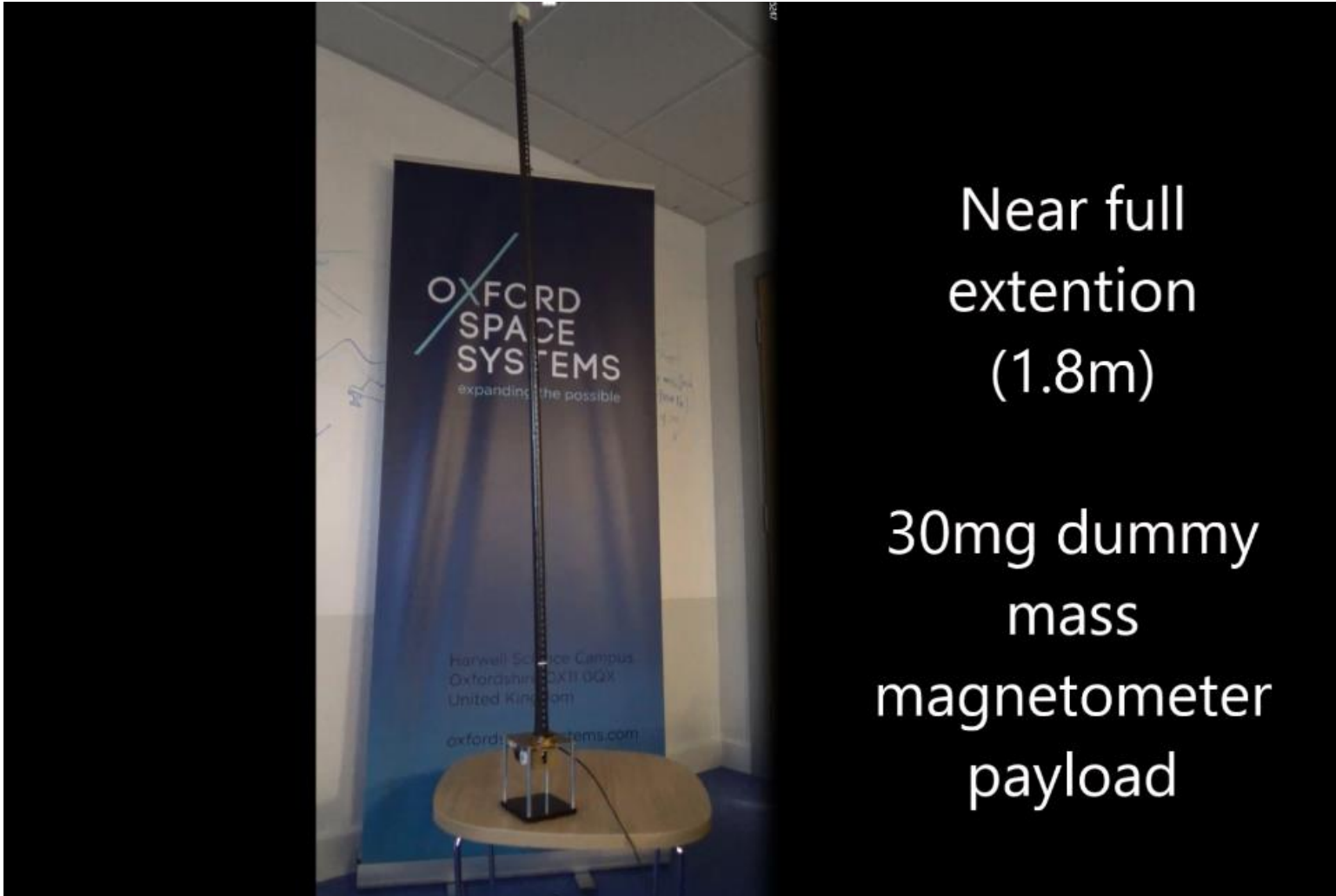

Video removed due  
to file size

AdChoices  [▶ UK Courses](#) [▶ Cubesat](#) [▶ The Mission](#) [▶ Satellites](#)

## TECH SPACE

# UK Space Agency's second CubeSat mission is taking shape

by Staff Writers  
London, UK (SPX) Mar 04, 2015

The UK Space Agency's next CubeSat mission, AISat Nano, is starting to take shape, following the selection of the mission's payloads. The suite of 3 payloads will be developed by UK academic-industrial partnerships that will use the mission for rapid and cost-effective demonstration of new and innovative space technologies.

AISat Nano is a joint space mission between the UK Space Agency and Algerian Space Agency (ASAL). In March 2014 the UK Space Agency and ASAL signed a Memorandum of Understanding (MoU) under which the two parties agreed to enhance collaboration in space programmes.



A specific action identified following the MoU was the establishment of a joint educational CubeSat development programme to be delivered by Surrey Space Centre (SSC), utilising its ties and heritage in the field.

The mission's payloads include:

### SpaceMag-PV Boom

This payload could significantly improve the range of science experiments that a CubeSat could carry by making advances in the field of booms - arms used to hold instrument sensors as far as possible from the spacecraft body to minimise interference.

SpaceMag-PV Boom will flight test the world's longest retractable CubeSat-compatible boom which will be able to deploy up to 2 metres in length from a volume the size of a cigarette packet. This technology could also form the basis of de-orbit systems for future missions.

The payload also carries a magnetometer, one of the most compact of its class, to carry out measurements of the Earth's magnetic field. Also on the payload will be RadFET radiation monitors, and test tokens of a revolutionary flexible solar cell material. The payload is led by [Oxford Space Systems Ltd](#), collaborating with partners including RAL Space and Bartington Instruments Ltd.

# Scalable Telescopic CFRP Booms

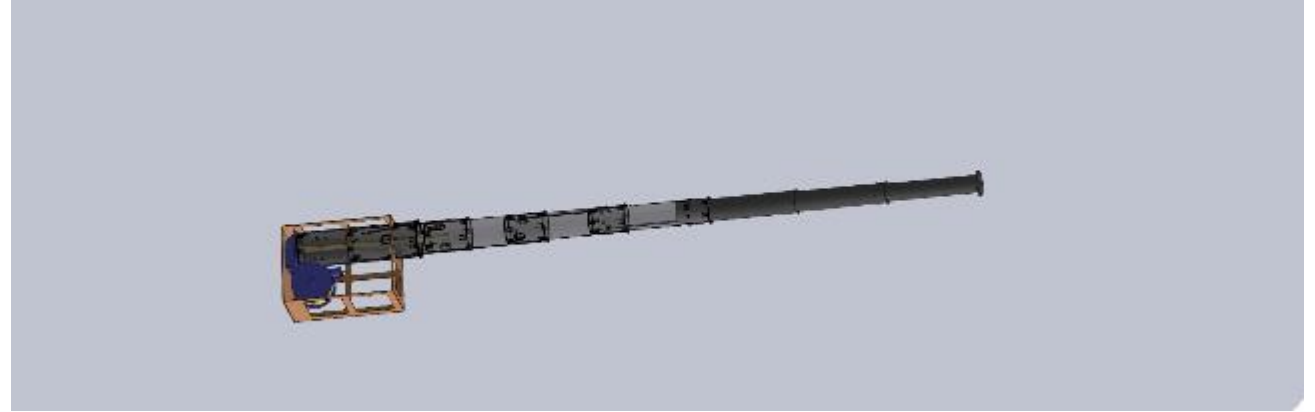
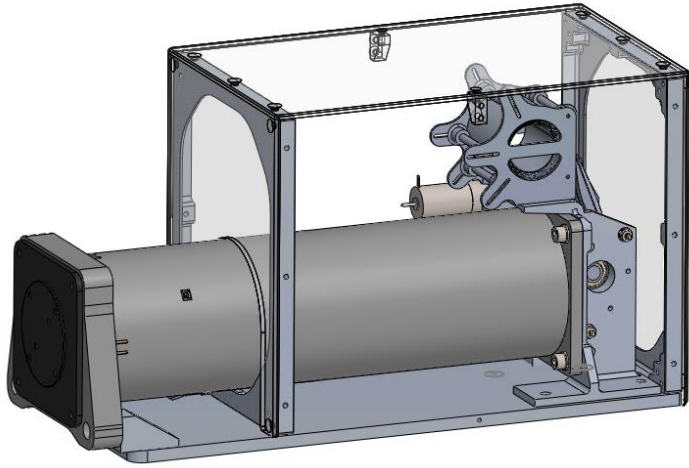

Videos removed

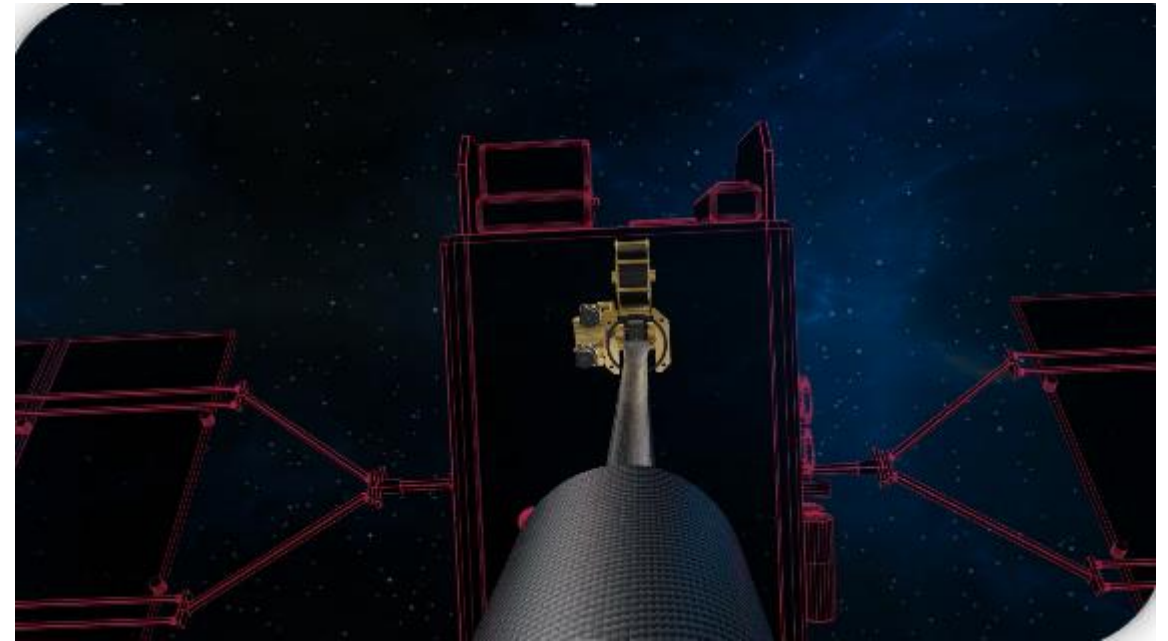
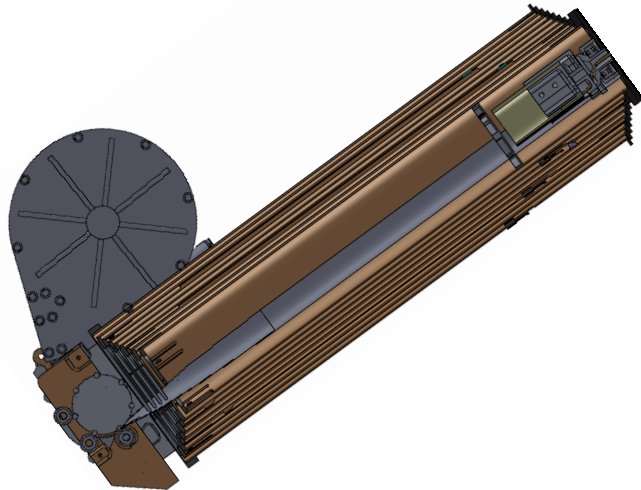
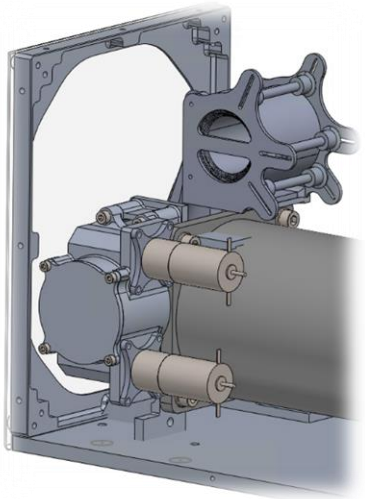

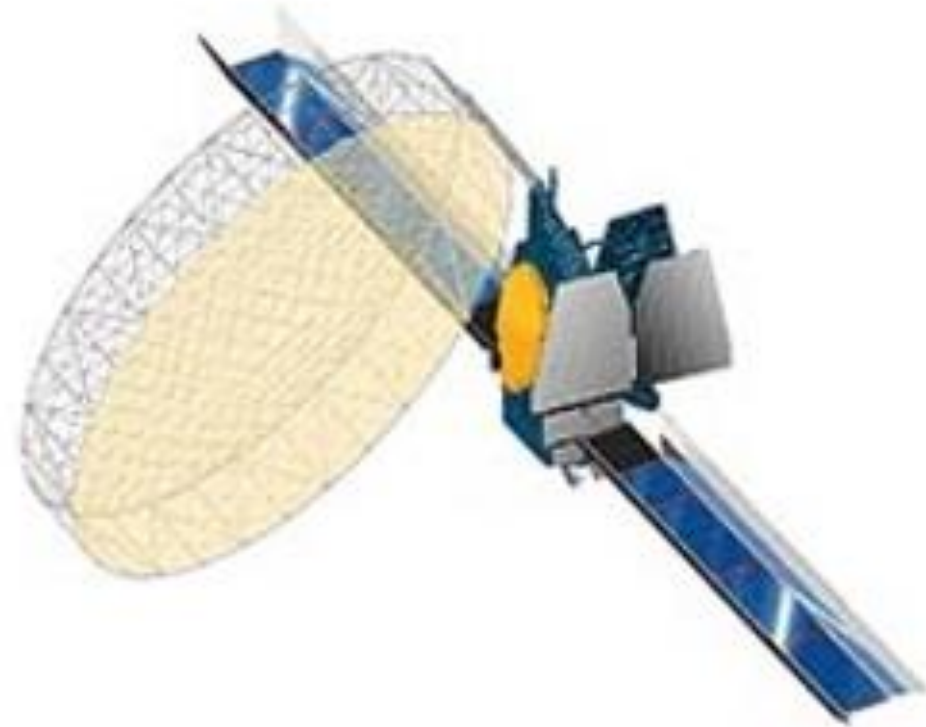

## LARGE DEPLOYABLE ANTENNAS

# Deployable Parabolic Antennas

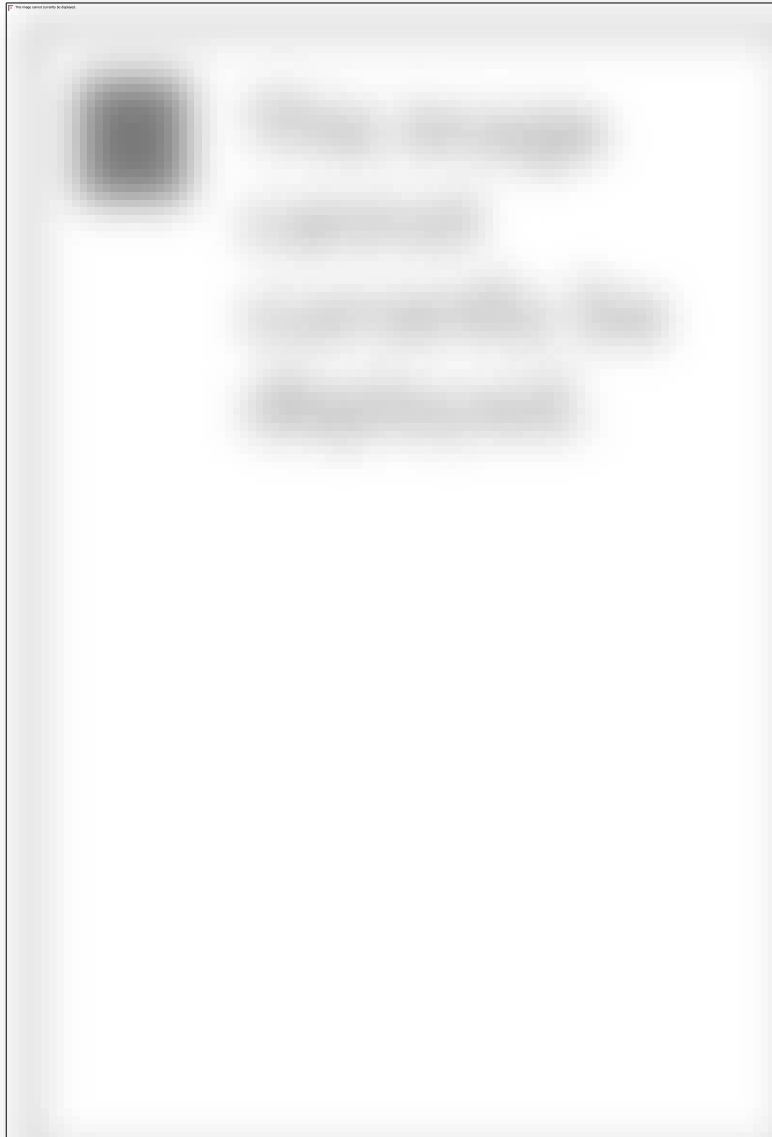

- ESA identified strategic requirement for large deployable antennas for data comms & earth observation
- OSS design highly commended by ESA
- OSS team are developing a next generation LDA able to support market demand for higher frequencies:
  - ✓ novel reflector surface material
  - ✓ high stowage efficiency
  - ✓ scalable design
  - ✓ strong IP

**conventional reflector  
surface material- metal mesh**

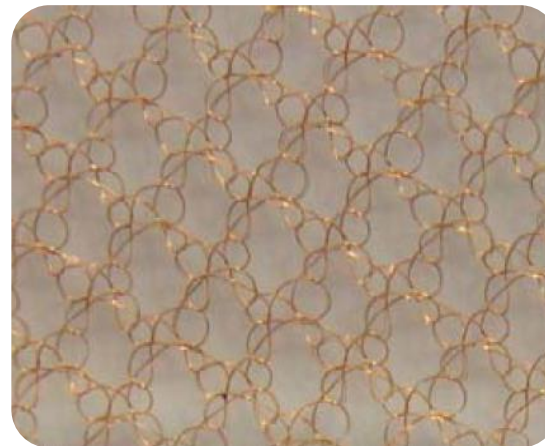

**Tri-axial fibre based flexible surface**

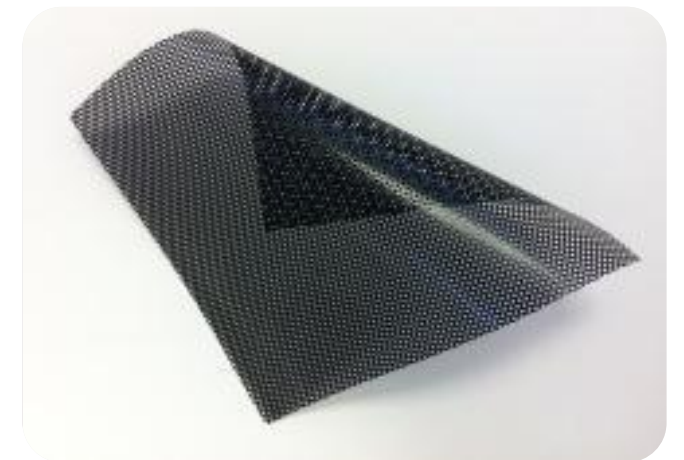

# Value Proposition & Working with Japan

- ❑ Oxford Space Systems (OSS) is developing a range of novel flexible composites & highly scalable products that can compliment Japanese developments (flexible solar arrays, flexible antennas etc)
- ❑ The OSS technology is very cost-competitive and can be rapidly developed by a highly motivated and agile team.
- ❑ As an early stage business, OSS has no 'in-grained' culture that presents a barrier to working in collaboration with Japanese partners and co-developers.
- ❑ OSS believes that long-term relationships built upon trust and a mutually beneficial relationship are essential.
- ❑ OSS will seeks to exploit mutual developments outside of Japan for the benefit of all parties – an entrepreneurial 'injection' to assist with exploitation overseas.

